

AFLEX[®]



PRODUCT

Aflex Bellows Assemblies

GEB

GIMBAL EXPANSION BELLOWS



An Aflex Gimbal Expansion Bellow (GEB) consists of a bellow fitted with flanges and gimbal hardware. The gimbal hardware fully restrains the bellows and allows for only angular rotation on two planes simultaneously.

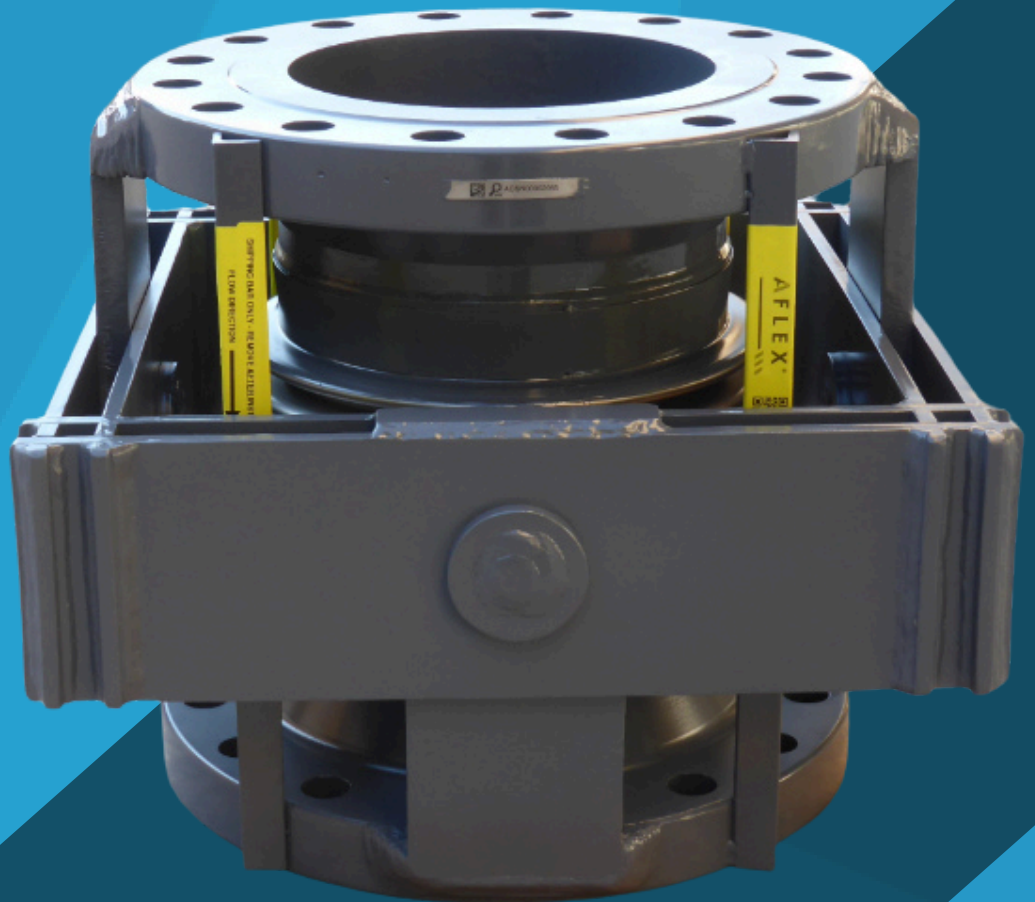

Commonly, two GEB units are installed on a pipe leg to absorb large amounts of lateral deflection in multi-plane piping systems.

The Gimbal structure also restrains the pressure thrust generated by the bellows, meaning the pipeline does not require high load anchors, as the GEB only generates low forces on the piping system.

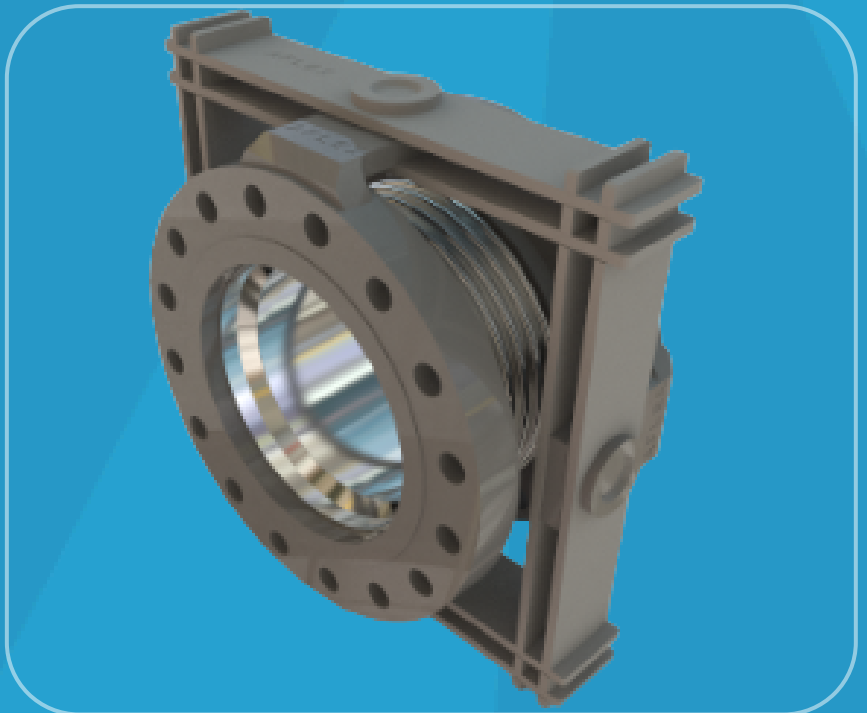

GEB – Gimbal Expansion Bellows

Applications	Common Pressure
Steam lines	1000kPa
Oil and gas	1200kPa
Water lines	1600kPa
Data centre piping	1400kPa
Cooling lines	1000-1600kPa
Heating lines	1000-1600kPa

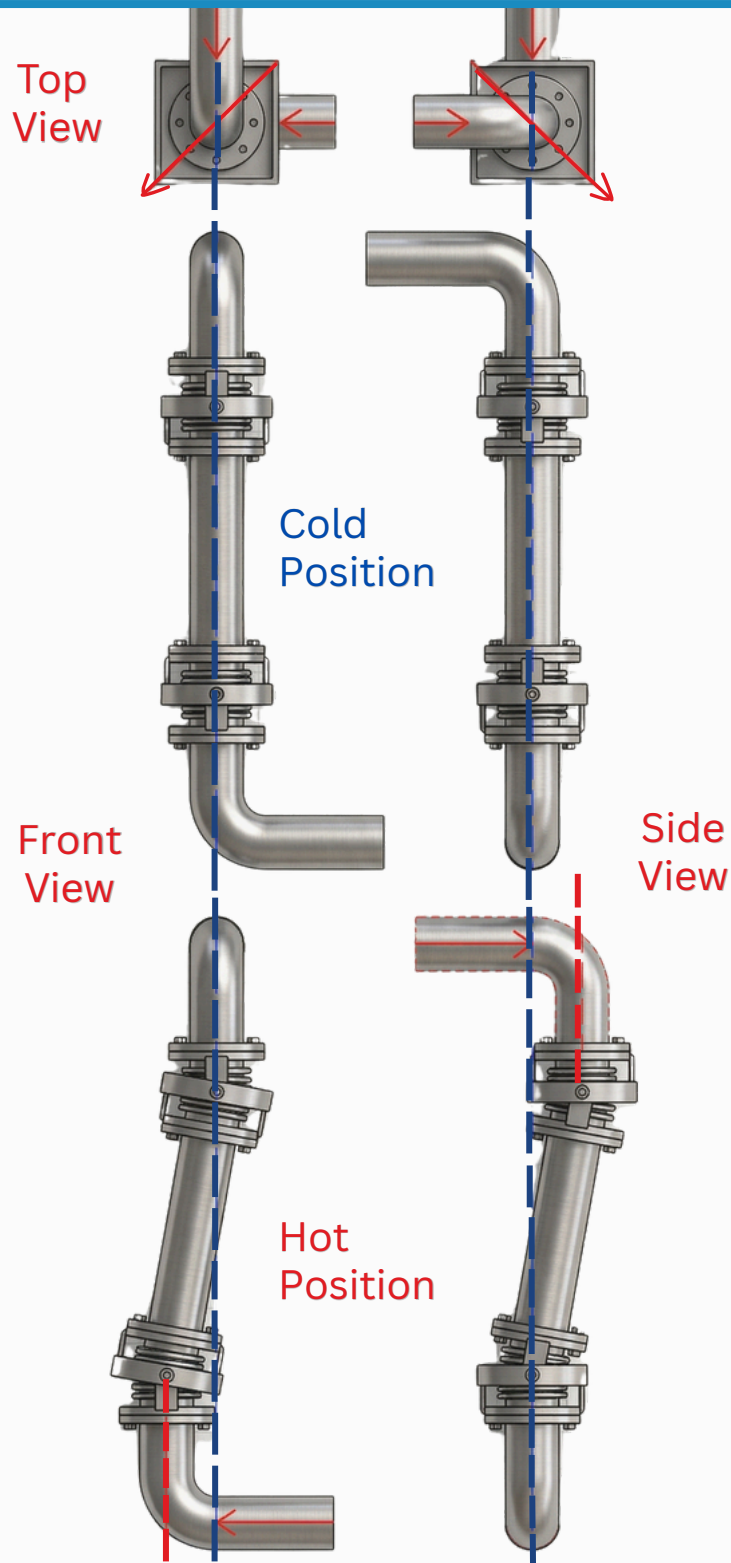

EXPLORE MORE
PRODUCT GALLERY



AFLEX®

- ☎ (02) 9457 7530
- ✉ sales@aflex.com.au
- 🌐 www.aflex.com.au
- 📍 Units 14-17, 12-14 Beaumont Road,
Mount Kuring-gai NSW 2080

